

Dill®

1504 -
1510

TPMS Trailer Kit



Key Features:

- Visual and audible warnings
- Set desired PSI level
- Mounts to windshield or dashboard
- Alerts when tire pressure is too low
- Alerts when tire pressure is too high
- Alerts when tire temperature is too high



Valve stems pictured may differ from stems packed in kit.

Thank you for purchasing Dill TPMS Trailer Kit. Properly inflated tires increase fuel economy, reduce tire wear and increase handling. A warning system to notify you of an underinflated tire will help give you time to respond prior to potentially damaging your tire or trailer.

For more information visit our website at <http://www.trailertpms.com>

Table of Content	Page
1. Setting Up the System	3
1.1 Transmitter Installation	3
1.2 Install the Display	3
1.3 Setting the Baseline (Cold Inflation) Pressure	3
1.4 Using the External Antenna—RF Interference	4
2. Transmitter Installation:	6
3. System Overview	7
3.1 System Components	7
3.2 How the System Works	7
3.3 Normal Monitoring	9
3.4 Warnings	9
3.5 Display Indicator and Controls	11
3.6 Transmitter Components	11
3.7 Tire Rotation	12
3.8 Changing Number Of Wheel Positions	13
4. Specifications:	
4.1 Transmitter	14
4.2 Display Unit	14
4.3 Component Part Numbers	15

1.0 Setting Up the System

1.1 Transmitter Installation

Have a professional tire retailer install the valves with transmitters in the wheels. See section 2 for details. Each transmitter has a unique ID and needs to be installed in the same corresponding position as noted in Figure on page 13.

1.2 Install the Display

- 1.2.1 Install the supplied antenna to your display unit located at the back of the unit.
- 1.2.2 Use the display mount to affix the display unit on the windshield or dashboard. Do not block the driver's view. Adjust the viewing angle of the display, if necessary.
- 1.2.3 Plug the power cord into the display unit and plug the adapter into auxiliary power supply or hardware to vehicle electrical system.



FIGURE 1



NOTE:

For hardwired connection, black wire is ground and red is positive.

- 1.2.4 If your tire cold inflation pressure is 35 psi, you are done. If it is something besides 35 psi, complete section 1.3.

1.3 Setting the Baseline (Cold Inflation) Pressure

- 1.3.1 Set the pressure in all tires to the recommended cold inflation pressure.
- 1.3.2 Plug the power cord into the display unit and plug the adapter into auxiliary power supply.



1.3.3 Hold down the "R/D" button until you hear a beep (5 seconds and an "A" appears in the upper right hand of the screen)



1.3.4 Press "SET" button.
The "A" changes to a "D", the display will show "dd"

FIGURE 2

The display is now in learn mode and will store the cold inflation pressure of each tire once it receives a signal from it. The process may take up to 8 minutes. If all pressures are not received in 8 minutes, the display will shift back to the monitoring mode. The tire positions that did not register will display 00. You will need to repeat section 1.3.2 until a signal is received from all tire positions. Driving the vehicle will speed up the process, since when rotating; the transmitters send a signal more frequently than when the vehicle is stationary.

If repeating the baseline pressure setting process does not get all the tires positions to register, or the display to receiving a signal on an intermittent basis, experimentation with an external antenna and/or signal booster will be necessary to get the unit to function.

1.4 Using the External Antenna - RF Interference

The system has been tested to work 40 feet, along line-of-sight paths. However, tire construction, vehicle construction, electronic interference and low temperatures all reduce this distance. RF signals are subject to interference from many types of signals and products, which can cause errors in the operation of the product. As with cell phones and other types of electronics using RF signals, signal interruption can occur and cause lost signal transmission.

External Antenna Installation

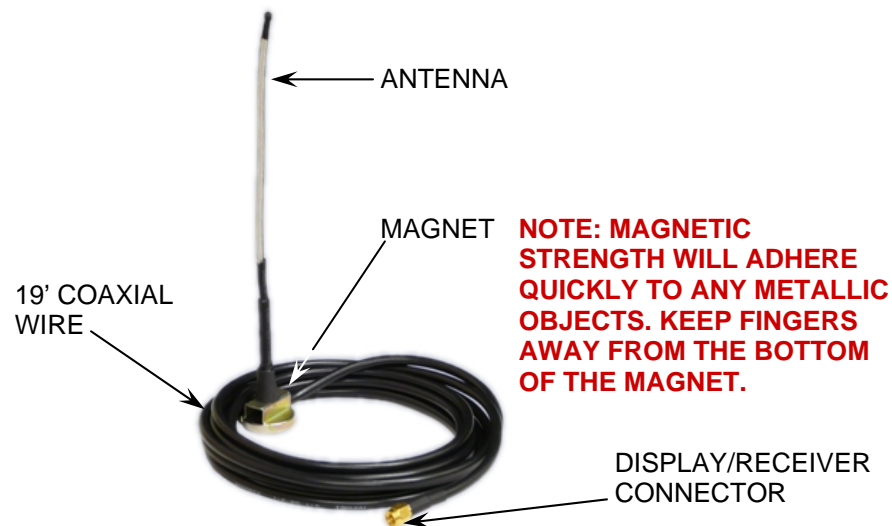

FIGURE 3

Remove the original antenna from the back of the display unit and replace it with the coaxial wire antenna via display connector.

Install the magnet/antenna at the rear of the vehicle, which will give it the nearest proximity to the transmitters. Thus, increasing signal reception between the display/receiver and transmitters.

Do not install the magnet/antenna directly on the trailer.

It is the installer/end user's discretion how to install the antenna and coaxial wire from the exterior and interior of the vehicle cabin.

Installing the external antenna involves a small degree of experimentation for maximum signal reception. Temporarily connect the antenna cable to the display, passing the cable through the vehicle's door or window. This temporary connection allows you to test the antenna's location. If the location you have selected for the antenna has difficulty in picking up signals from all tire locations, change the antenna's location slightly and continue to test. When signals from all tire locations report, install the antenna permanently in the vehicle.

Caution: Stay away from transmission, oil and exhaust lines avoiding the inherent heat from those locations which can melt the coaxial cable.

If proper reception is not achieved with the external antenna, a signal boost will be required.

A signal booster is an optional part for RV's, fifth wheels and tow-vehicles and trailers. It enhances the signal from the transmitters. A signal booster is recommended to effectively receive the signals from each transmitter, when there may be interference from electronics, RV construction, length, etc.

2.0 Transmitter Installation

Before installation into the rim hole, you must assemble the transmitter and valve stem together.

2.1 Unscrew the hex nut and remove the metal washer from the valve stem.

2.2 Place the valve stem onto the transmitter and use the lock washer & screw to hold valve stem against the transmitter body.

Note: DO NOT TIGHTEN THE SCREW.

2.3 Insert the valve stem through the rim hole and verify that the rubber grommet is seated against the rim hole surface.

2.4 Adjust the angle of the transmitter body and verify the transmitter is resting flat against the wheel rim surface.

2.5 Tighten the screw at 35 inch pounds into the valve stem at the same time verify 3 conditions:

2.5.1 At least one of the transmitter's feet always contacts the rim surface.

2.5.2 The grommet is fully seated against the valve hole.

2.5.3 From the outside of the wheel, the valve stem is perpendicular to the rim's valve hole.

2.6 Place the metal washer and hex nut on the valve stem and turn the hex nut clockwise until the rubber grommet is pressed against the wheel rim surface.

2.7 Tighten the hex nut 35 to 40 inch pounds of torque to secure the valve stem to the rim. Verify at least one of the transmitter's feet has direct contact on the wheel rim surface. If not, uninstall the transmitter and redo it from 2.5.

2.8 Lock the wheel rim on the tire changer. Apply lubricant on both tire beads and rim. Mount the lower tire bead on the rim. Ensure that the tire bead does not touch the electronic module during mounting.

2.9 Mount the upper tire bead the same way and inflate the tire to standard cold inflation pressure. Avoid damaging the antenna.

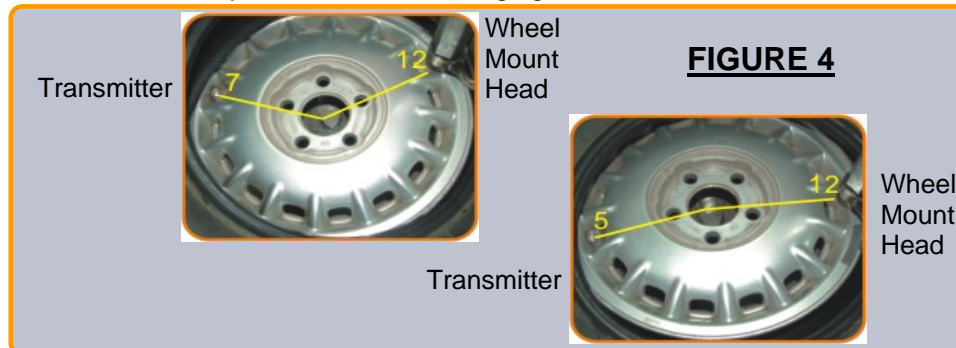

Note: The grommet, metal washer, hex nut and valve core must be replaced at each tire change.

2.10 Apply soap suds or commercial leak detection solution on the valve tip, grommet / rim seal. If no leakage is found, install the valve cap. Other wise, re-inspect and resolve leak issue.

2.11 Dynamically balance the wheel before it is put back on the vehicle.



FIGURE 5



3.0 System Overview

The TPMS trailer kit monitors tire pressure and temperature. It will provide warnings about abnormal conditions such as low pressure, high pressure, and high temperature.

3.1 System Components

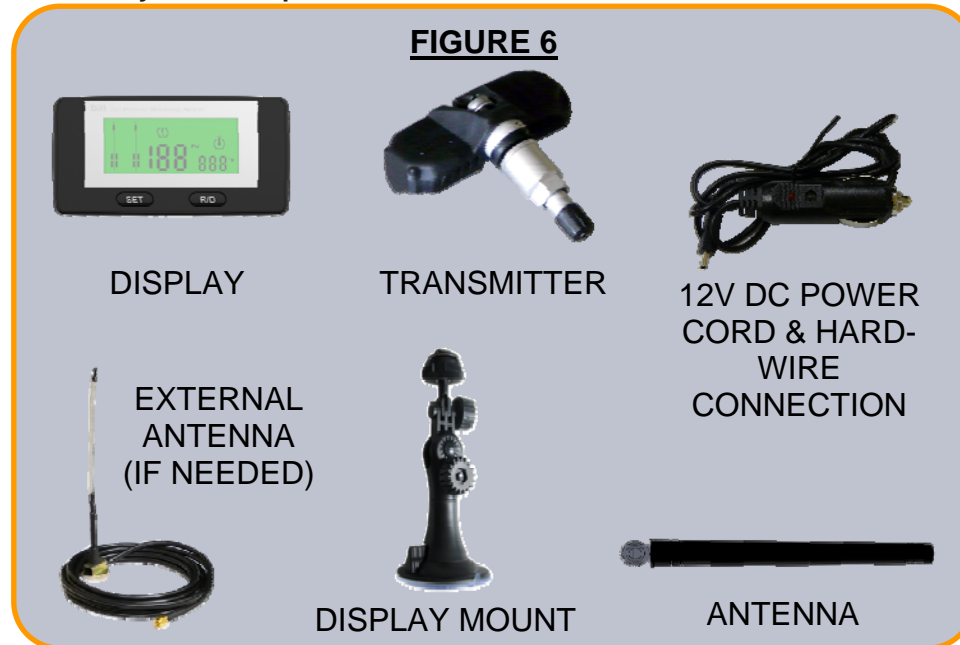

3.2 How the System Works

A transmitter connected to a valve stem is installed in each wheel, which monitors pressure and temperature conditions inside each tire of the vehicle. This data is wirelessly sent to the receiver that is installed on the vehicle. The receiver displays the pressure and temperature for each tire position. When an abnormal condition is detected, the display will alert the driver.

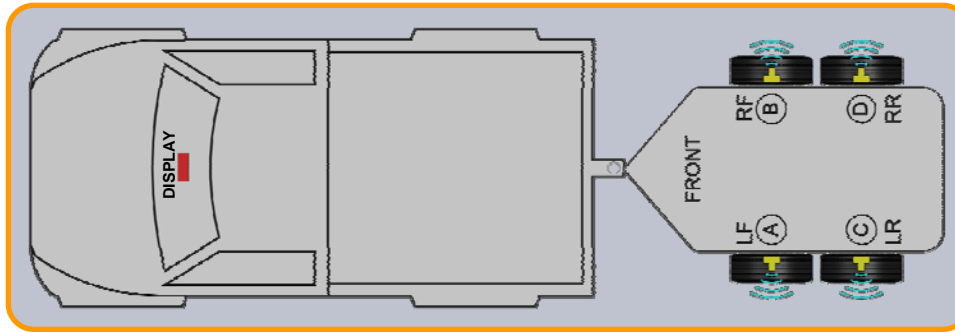

FIGURE 7

The display is preprogrammed to provide a warning if the pressure drops 20% below or 30% above the cold inflation pressure. It will also give a high temperature warning if the temperature exceed 176°F. The high temperature warning point is not adjustable.

The system is shipped with the baseline (cold inflation) pressure set at 35 psi. At this setting, the display will provide a low pressure warning at 28 psi and a high pressure warning at 46 psi. You can set the baseline pressure (see Setting the Baseline (Cold Inflation) pressure in Setting up the System on page 3) up to 144 psi and the display will automatically provide a low pressure warning at 20% below and 30% above the baseline setting.

Examples:

Cold Inflation Pressure	Low Pressure Alarm	High Pressure Alarm
45 psi	36 psi	59 psi
65 psi	52 psi	85 psi
90 psi	72 psi	117 psi

3.3 Normal Monitoring

3.3.1 Stationary State:

The transmitter will transmit tire pressure and temperature data to the display at 2-minute intervals. As the data is received, the display will refresh.

3.3.2 Moving State:

The inertial switch of transmitter is on when the speed exceeds 16mph.

The transmitter will transmit tire pressure and temperature data to the display at 30-second intervals. As the data is received, the display will refresh.

3.4 Warnings

3.4.1 Low Pressure Warning

If the pressure in a tire is 20% lower than the cold inflation pressure setting, then the following will occur:

1. The display will show the pressure of the abnormal tire and the digits will flash.
2. An audible alert warning sound will be heard.
3. The abnormal icon will show up.
4. The system will only display the abnormal tire. By pressing "SET" or "R/D", you can temporarily view other tires.

The system will not return to normal monitoring until the problem(s) is corrected.

3.4.2 High Pressure Warning

If the pressure in a tire is 30% higher than the cold inflation pressure setting, then the following will occur:

1. The display will show the pressure of the abnormal tire and the digits will flash.
2. An audible alert warning sound will be heard.
3. The abnormal icon will show up.
4. The system will only display the abnormal tire. By pressing "SET" or "R/D" you can temporarily view other tires.

The system will not return to normal monitoring until the problem(s) is corrected.

3.4.3 High Temperature Warning

When the temperature in a tire exceeds 176°F, the following will occur:

1. The display will show the temperature of the abnormal tire and the digits will flash.
2. An audible alert warning sound will be heard.
3. The abnormal icon will show up.
4. The system will only display the abnormal tire. By pressing "SET" or "R/D" you can temporarily view other tires.

The system will not return to normal monitoring until the problem(s) is corrected.

- ### 3.4.4 Monitor System Malfunction
- if the display does not receive a signal from a transmitter(s) in the tires for more than 30 minutes*, the display screen will display as dashed lines "- - -".

NOTE:

When the dash lines "- - -" appears, it will not be dismissed from the display even if you restart the unit. When the receiver (display unit) receives an updated signal from the transmitter(s), the dashed lines will disappear.

If you are not receiving a signal from the transmitter(s), verify the following conditions.

1. Power off the display unit and restart the system. The system will return to normal monitoring after properly receiving signals from the transmitter(s).
2. Check your antenna connection.
If the display unit is working properly and it still does not receive a signal from the transmitter(s), then the transmitter(s) and id module(s) must be replaced simultaneously.
3. "Er" indicates there is no chip in the position, the chip is not correctly inserted into the display or the chip is not functioning.

3.5 Display Indicator and Controls

FIGURE 8

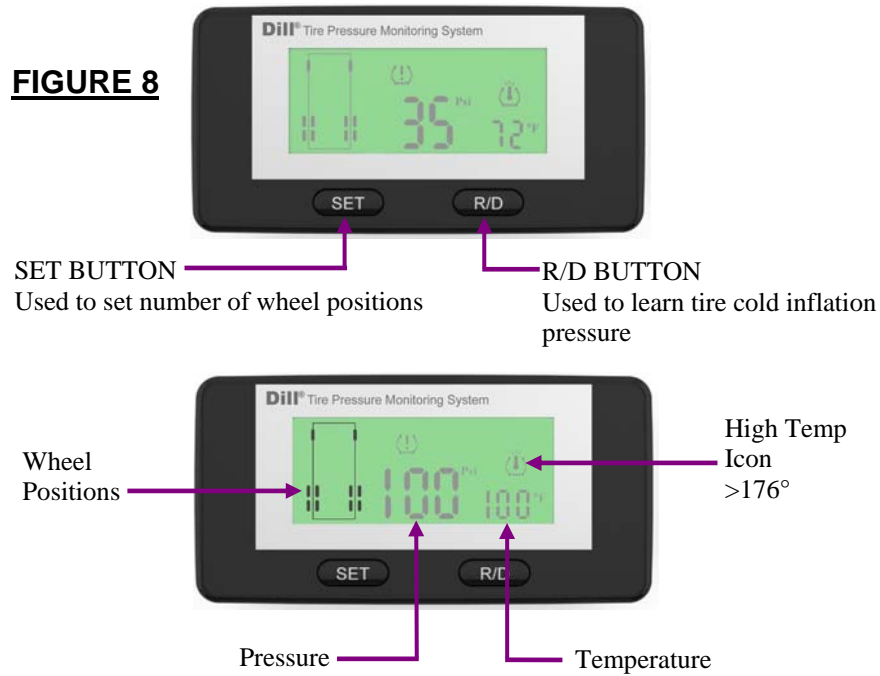

3.6 Transmitter Components

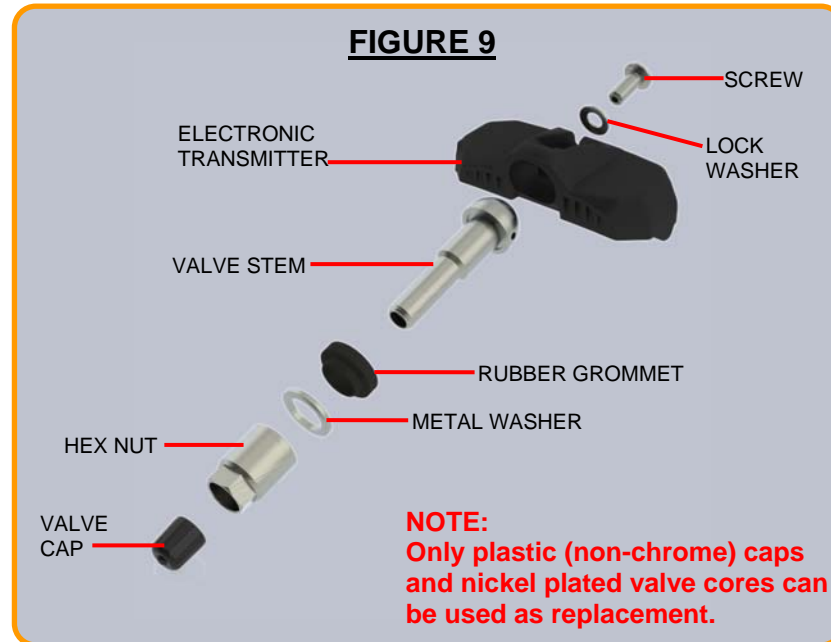

3.7 Tire Rotation

Every transmitter has a unique 8 character ID that is associated with a chip in the display. An alpha label is also added to each transmitter and chip as an additional identifier. As tires are rotated, the chips are moved to the corresponding position in the display. No reprogramming is necessary. For example if you move the right front tire (RF) to the rear (R1) you would move the chip in the back of the display from RF to R1 and move R1 to RF.

FIGURE 12

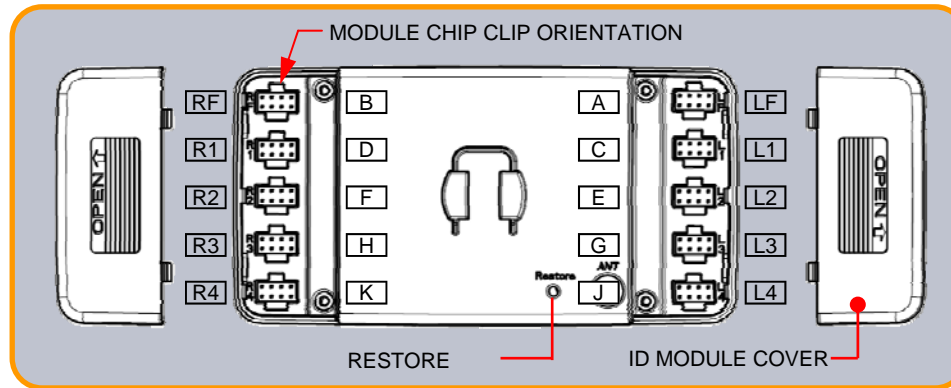

Pressing the restore key, resets the baseline to 35 PSI

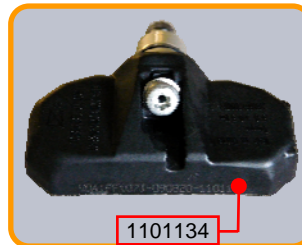

Transmitter I.D.
Location

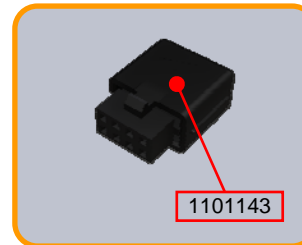

Chip I.D.
Location

3.8 Changing Number Of Wheel Positions

The number of wheels in the vehicle can be set as 4, 6a, 6b, 8 or 10 as noted in Figure 13. The number of wheel position is pre-set. However, if you add positions use the following procedure to change it.

To change the number of wheels, perform the following:

- 3.9.1 Press and hold the "SET" button for 5 seconds to enter the wheel number configuration setting, a 'beep' will sound and the current wheel configuration will appear on the screen.
- 3.9.2 Press the "R/D" button to select among 4, 6a-wheel, 6b-wheel, 8-wheel or 10-wheel configuration. The position and the number of the wheels will appear on the screen.
- 3.9.3 Press and hold the "SET" button for 5 seconds to complete the selection. A 'beep' will sound when it's complete.

FIGURE 13

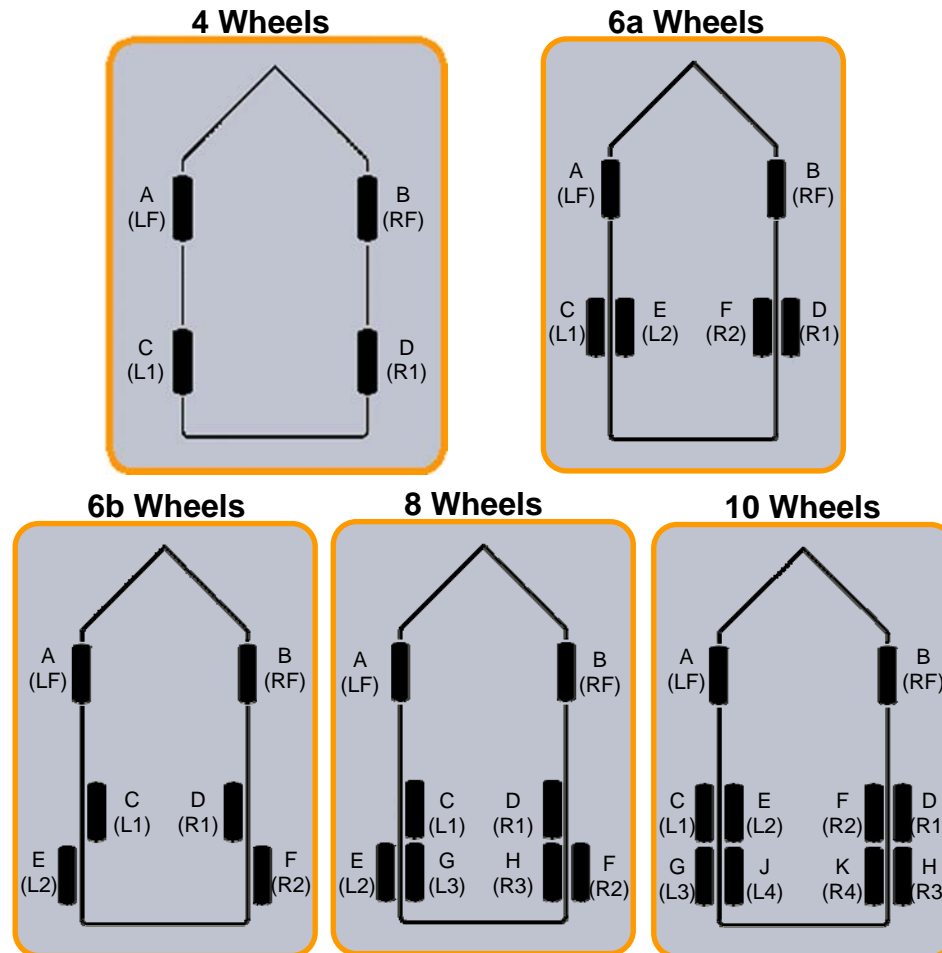

4. Specifications

4.1 Transmitter

- Weight: 1.25 oz. (35g)
- Dimensions: 0.59" x 2.50" x 1.11" (1.5 x 2.8 x 6.4 cm)
- Operating Temperature Range: -40°F to 257°F (-40°C to 125°C)
- Pressure Accuracy: ± 2 PSI (± 14 Bar)
- Temperature Accuracy: ± 5.4 °F (± 3 °C)
- Battery life: 5 to 7 years
- Maximum Sensing Pressure: 188PSI (12.96Bar / 1296Kpa)
- Maximum Cold Inflation Pressure: 144PSI (9.93Bar / 993Kpa)
- Frequency: 433.92MHz

4.2 Display

- Power Consumption: 130mW (regular) / 230mW(Max)
- Power Supply: DC12 Volt
- Weight: 1.06oz. (30g)
- Dimensions: 3.35" x 1.97" x 0.79" (8.5 x 5 x 2 cm)
- Pressure resolution: 0.1PSI (.01Bar / 1Kpa)
- Temperature resolution: 2°F (1°C)

4.3 Component Part Numbers

PART NUMBER	DESCRIPTION
1900	TPMS DISPLAY UNIT, MOUNT & POWER CORD
9300	TPMS TRANSMITTER AND CHIP
1905	SIGNAL BOOSTER

4.4 Available Valve Configurations

WHEEL RIM HOLE SIZE: .453"

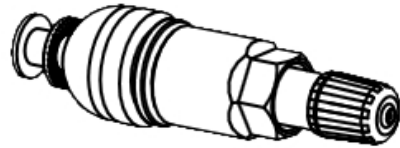

P/N: TP 416

WHEEL RIM HOLE SIZE: .625"

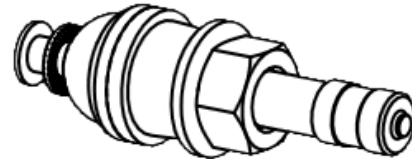

P/N: TP 501

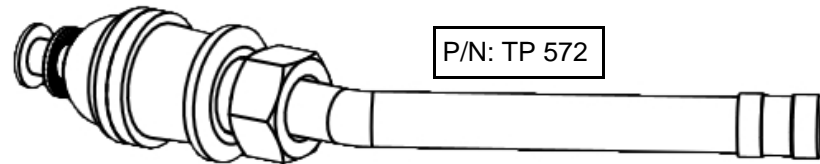

P/N: TP 572

WHEEL RIM HOLE SIZE: .390"

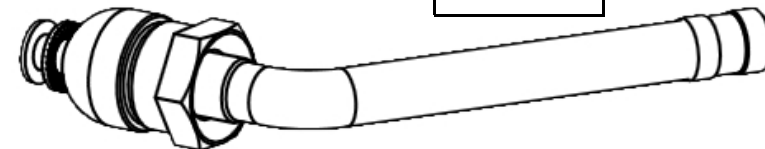

P/N: TP 555

Dill Air Controls Products

1500 Williamsboro Street Oxford, North Carolina 27565

Trailer Kits—Tire Pressure Monitoring Systems

**Customer Service:
800-815-3455**

www.dillvalves.com

~ Quality Automotive Products Since 1909 ~